

Instructions

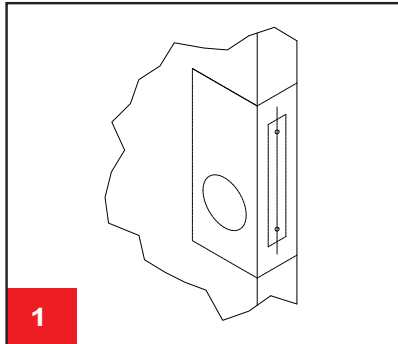
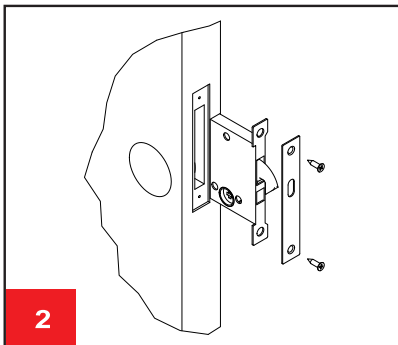

1. Door Preparation – Installation height from the finished floor height is recommended between 900mm – 1100mm.

- Mark installation centrelines on both door faces and the door edge in accordance with the template overleaf.
- Mark and prepare a mortise of 85mm (h) x 12mm (w) x 60mm (d) for the lock case.
- Mark and chisel out for the lock body face plate 120mm (h) x 20mm (w) to a recess of 2mm. Use lock body faceplate as a template.

**2. Lock Installation**

- Mark and drill 2 x 49mm diameter holes for the turn activators. Drill from both sides of the door to meet in the middle.
- Ensure centre of the hole is perfectly aligned to suit the lock spindle hub. Drill from both sides.
- It is recommended that a 3mm pilot hole is drilled in the correct position firstly before enlarging the required hole to 49mm.
- Install lock body into mortise cut out and fix in place using screws provided.

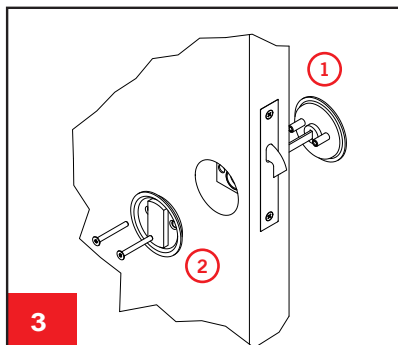
**3. Assembly Of Turns**

- Assemble the external privacy button flush pull with fixing posts into position (1) and then place into position the internal visible fix turn flush pull (2).
- Cut escutcheon connecting flat spindle to suit door thickness.
- Fasten the two flush pulls together using the metal thread screws provided.
- Ensure the hook lock bolt moves freely and readjust escutcheons if necessary.

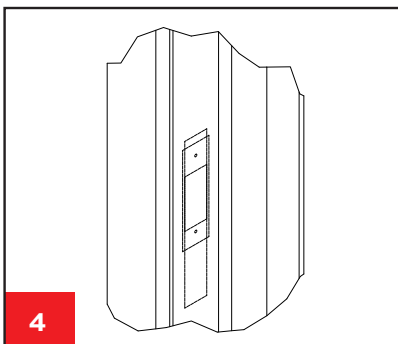
**4. Frame Keeper Preparation**

- Slide door into closed position. Mark centre of the lock bolt in retracted position on to frame. Centre of keeper hole is to be located centre of bolt.
- Position keeper plate and scribe around the outside and inner keeper hole.

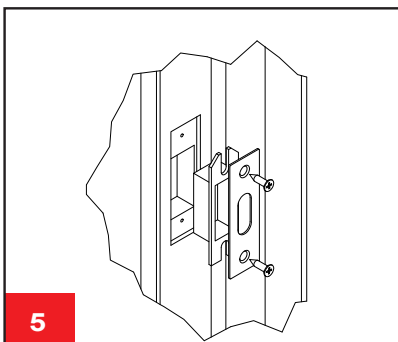
**5. Frame Keeper Installation**

- Mortise centre keeper hole to a depth of 20mm. Note: ensure mortise is cut low enough to clear the bolt when it is extended. Bolt extends outwards and downwards.
- Rout out strike plate to a depth of 3mm so that keeper plate is flush with frame surface.
- Rout out for strike box 42mm high X 20mm wide x 20mm deep.
- Fit and fasten the strike box and plate with two screws provided.

Mortise preparation dimensions

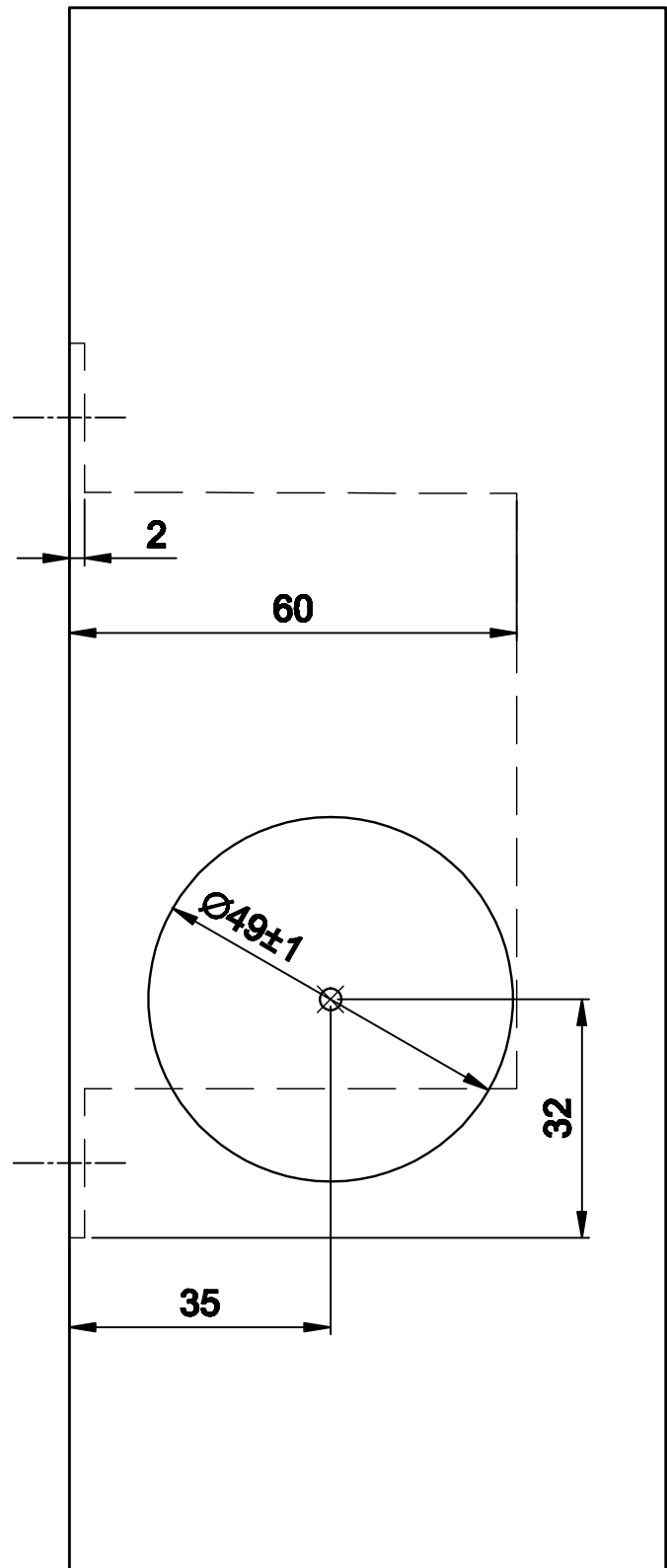
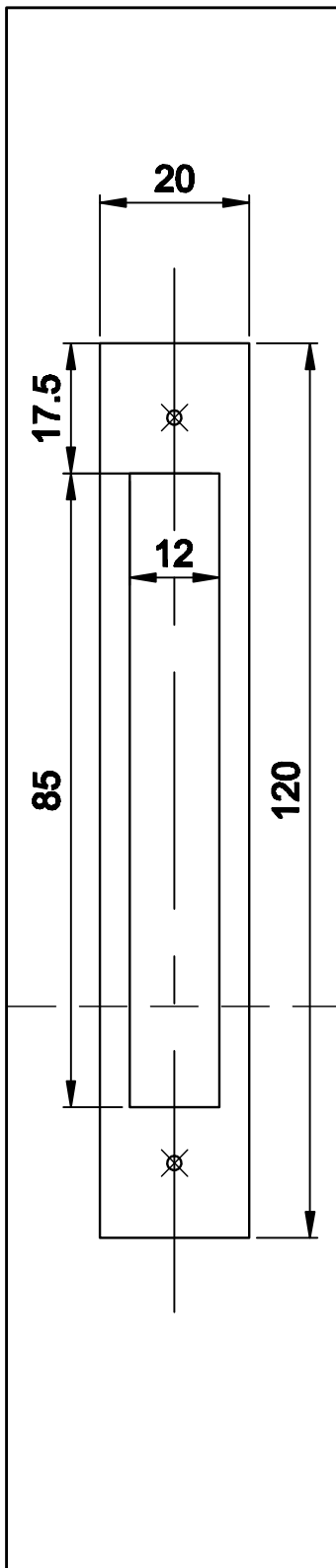

*Paper templates might distort. Only the indicated measurements are therefore obligatory.

*Subject to change without notice. AMD03015 06/15